

Technical Data

Vertical multistage centrifugal pumps

LCRI, LCRN 15

Performance Chart

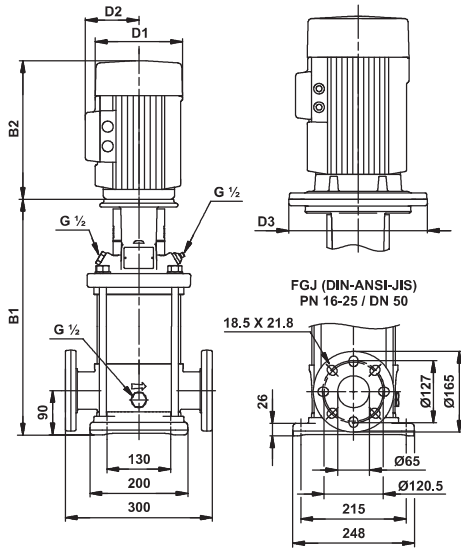

Pump Type	H.P.	kW	Q l/min m ³ /h	n = 2900 rpm					
				233.3	250.0	266.7	300.0	333.3	366.7
				14.0	15.0	16.0	18.0	20.0	22.0
LCRI ,LCRN 15/1	1.50	1.10	H mts.	12	12	11	11	10	9
LCRI ,LCRN 15/2	3.00	2.20		25	24	23	22	20	18
LCRI ,LCRN 15/3	4.00	3.00		37	36	35	32	30	26
LCRI ,LCRN 15/4	5.50	4.00		50	48	47	44	39	35
LCRI ,LCRN 15/5	5.50	4.00		62	60	59	54	49	44
LCRI ,LCRN 15/6	7.50	5.50		74	72	69	65	58	52
LCRI ,LCRN 15/7	7.50	5.50		87	84	82	76	70	62
LCRI ,LCRN 15/8	10.0	7.50		99	96	93	87	79	70
LCRI ,LCRN 15/9	10.0	7.50		112	108	105	98	89	80
LCRI ,LCRN 15/10	15.0	11.0		124	121	117	109	99	89
LCRI ,LCRN 15/12	15.0	11.0		149	146	140	131	119	106
LCRI ,LCRN 15/14	15.0	11.0		174	170	163	152	139	124
LCRI ,LCRN 15/17	20.0	15.0		211	206	198	185	169	151

Dimensions & Weights of LCRI, LCRN Pump

Pump type	Dimensions [mm]					Net weight [kg]	Gross weight [kg]	Gross volume [m ³]
	DIN flange		D1	D2	D3			
	B1	B1+B2						
LCRI ,LCRN 15/1	400	664	160	113	-	42.0	56.0	0.1428
LCRI ,LCRN 15/2	415	693	165	130	-	50.0	64.0	0.1428
LCRI ,LCRN 15/3	485	789	194	140	-	55.0	81.0	0.2650
LCRI ,LCRN 15/4	510	860	220	150	-	68.0	94.0	0.2650
LCRI ,LCRN 15/5	555	905	220	150	-	69.0	95.0	0.2650
LCRI ,LCRN 15/6	632	1042	262	177	300	91.0	117.0	0.2650
LCRI ,LCRN 15/7	677	1087	262	177	300	93.0	122.0	0.2996
LCRI ,LCRN 15/8	722	1132	262	177	300	97.0	126.0	0.2996
LCRI ,LCRN 15/9	767	1177	262	177	300	98.0	127.0	0.2996
LCRI ,LCRN 15/10	889	1431	304	225	350	130.0	176.0	0.4671
LCRI ,LCRN 15/12	979	1521	304	225	350	134.0	187.0	0.5402
LCRI ,LCRN 15/14	1069	1611	304	225	350	138.0	191.0	0.5402
LCRI ,LCRN 15/17	1204	1746	304	225	350	157.0	210.0	0.5402

Performance Curves

Vertical multistage centrifugal pumps

LCRI, LCRN 15

