

# Technical Data

## Vertical multistage centrifugal pumps

## LCRI, LCRN 3

Performance Chart

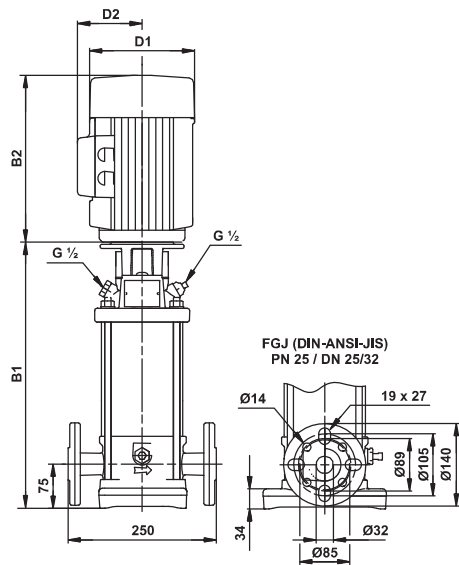

Pump Type	H.P.	kW	Q l/min m <sup>3</sup> /h	n = 2900 rpm					
				33.3	40.0	46.7	50.0	53.3	60.0
				2.0	2.4	2.8	3.0	3.2	3.6
LCRI, LCRN 3/2	0.50	0.37	H mts.	12	11	10	10	9	8
LCRI, LCRN 3/3	0.50	0.37		18	17	15	15	14	12
LCRI, LCRN 3/4	0.50	0.37		23	22	21	19	18	16
LCRI, LCRN 3/5	0.50	0.37		29	28	26	24	23	21
LCRI, LCRN 3/6	0.75	0.55		35	33	30	29	27	24
LCRI, LCRN 3/7	0.75	0.55		41	38	36	34	33	29
LCRI, LCRN 3/8	1.00	0.75		47	44	41	39	38	33
LCRI, LCRN 3/9	1.00	0.75		52	50	46	44	41	36
LCRI, LCRN 3/10	1.00	0.75		58	55	51	49	46	40
LCRI, LCRN 3/11	1.50	1.10		64	60	56	53	51	45
LCRI, LCRN 3/12	1.50	1.10		69	66	61	58	55	48
LCRI, LCRN 3/13	1.50	1.10		75	71	66	63	60	53
LCRI, LCRN 3/15	1.50	1.10		86	80	75	71	68	60
LCRI, LCRN 3/17	2.00	1.50		100	94	87	83	79	70
LCRI, LCRN 3/19	2.00	1.50		110	104	97	91	88	77
LCRI, LCRN 3/21	3.00	2.20		123	116	108	102	98	86
LCRI, LCRN 3/23	3.00	2.20		135	127	118	112	107	95
LCRI, LCRN 3/25	3.00	2.20		146	138	128	121	116	102
LCRI, LCRN 3/27	3.00	2.20		157	148	138	130	124	110
LCRI, LCRN 3/29	3.00	2.20		169	159	148	140	134	118
LCRI, LCRN 3/31	4.00	3.00		182	172	159	151	144	127
LCRI, LCRN 3/33	4.00	3.00	193	182	170	161	154	136	
LCRI, LCRN 3/36	4.00	3.00	211	199	185	176	168	148	

Dimensions & Weights of LCRI, LCRN Pump

Pump type	Dimensions [mm]				Net weight [kg]	Gross weight [kg]	Gross volume [m <sup>3</sup> ]
	DIN flange		D1	D2			
	B1	B1+B2					
LCRI, LCRN 3/2	282	495	143	106	19.0	29.0	0.1030
LCRI, LCRN 3/3	282	495	143	106	19.0	29.0	0.1030
LCRI, LCRN 3/4	300	513	143	106	19.0	29.0	0.1030
LCRI, LCRN 3/5	318	531	143	106	20.0	30.0	0.1030
LCRI, LCRN 3/6	336	549	143	106	21.0	31.0	0.1030
LCRI, LCRN 3/7	354	567	143	106	21.0	31.0	0.1030
LCRI, LCRN 3/8	378	642	160	113	24.0	38.0	0.1428
LCRI, LCRN 3/9	396	660	160	113	24.0	38.0	0.1428
LCRI, LCRN 3/10	414	678	160	113	25.0	39.0	0.1428
LCRI, LCRN 3/11	432	696	160	113	27.0	41.0	0.1428
LCRI, LCRN 3/12	450	714	160	113	28.0	42.0	0.1428
LCRI, LCRN 3/13	468	732	160	113	28.0	42.0	0.1428
LCRI, LCRN 3/15	504	768	160	113	29.0	43.0	0.1428
LCRI, LCRN 3/17	556	834	165	130	36.0	50.0	0.1428
LCRI, LCRN 3/19	592	870	165	130	37.0	55.0	0.1825
LCRI, LCRN 3/21	628	906	165	130	38.0	56.0	0.1825
LCRI, LCRN 3/23	664	942	165	130	39.0	57.0	0.1825
LCRI, LCRN 3/25	700	978	165	130	40.0	58.0	0.1825
LCRI, LCRN 3/27	736	1014	165	130	41.0	59.0	0.1825
LCRI, LCRN 3/29	772	1050	165	130	42.0	60.0	0.1825
LCRI, LCRN 3/31	812	1116	194	140	47.0	76.0	0.2996
LCRI, LCRN 3/33	848	1152	194	140	47.0	76.0	0.2996
LCRI, LCRN 3/36	902	1206	194	140	49.0	78.0	0.2996

# Performance Curves

Vertical multistage centrifugal pumps

## LCRI, LCRN 3

